



02166479486

0912 8448763

0919 0345384

24 ساعته حتی تعطیلات

 **VALFTEK**®



**BONETTI**®

GLOBE VALVES

## GLOBE VALVES

Tip : BGV  
 PN 16 Cast Iron (JL 1040)  
 PN 25 Nodular Cast Iron (JS 1049)  
 Flanged

Sizes : DN 15 – DN 200  
 Pressure Ratings : PN 16 / PN 25 ( DIN 2401 )  
 Dimensions : acc. to DIN 3202- F1 & TS EN 558-1  
 Connections : Flanged to TS ISO 7005-2 , DIN EN 1092-2  
 Temperature Range : -10 +300 °C (PN 16) , -10 +350 °C (PN 25)  
 Applications : Water, hot water, superheated water, comp.air, steam, non-corrosive fluids

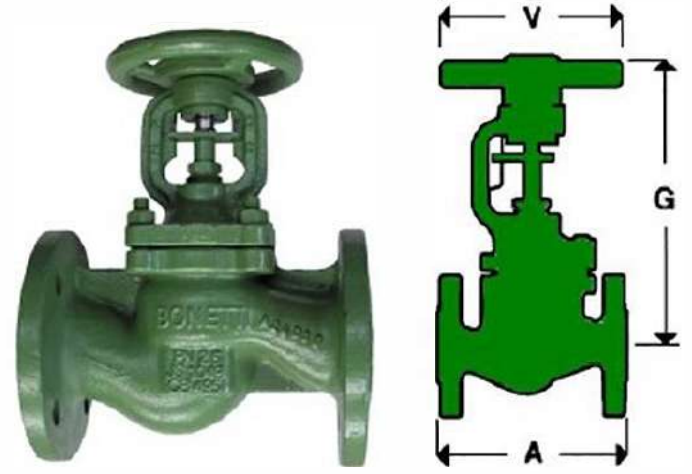

VALVE		DIMENSIONS			Stroke mm	FLANGE DIMENSIONS										PN 16/25 WEIGHT kg
Tip	DN mm	A mm	G mm	V mm		PN 16					PN 25					
					D mm	b mm	z	d mm	k mm	D mm	b mm	z	d mm	k mm		
BCV	15	130	200	125	8	95	14	4	14	65	95	16	4	14	65	4,3
BGV	20	150	200	125	8	105	16	4	14	75	105	18	4	14	75	5,0
BGV	25	160	210	125	11	115	16	4	14	85	115	18	4	14	85	6,2
BGV	32	180	210	125	11	140	18	4	19	100	140	18	4	19	100	7,2
BGV	40	200	225	150	15	150	18	4	19	110	150	18	4	19	110	9,8
BGV	50	230	230	150	17	165	20	4	19	125	165	20	4	19	125	12,2
BGV	65	290	250	175	18	185	20	4	19	145	185	22	8	19	145	17,5
BGV	80	310	260	175	21	200	22	8	19	160	200	24	8	19	160	20,6
BGV	100	350	340	225	26	220	24	8	19	180	235	24	8	23	190	33,9
BGV	125	400	360	225	33	250	26	8	19	210	270	26	8	28	220	52,1
BGV	150	480	405	300	42	285	26	8	23	240	300	28	8	28	250	72,3
BGV	200	600	500	400	53	340	30	12	23	295	360	30	12	28	310	107,5
BGV	250	730	650	600	70	405	32	12	28	355	425	32	12	31	370	320

D: Flange dia b: flange thickness z: hole no. d: Hole dia. k: Hole axis dia.

Part No / name	Material	
	PN16	PN25
1 Body	JL 1040 (GG 25)	JS 1049 (GGG 40.3)
1.1 Seat	AISI 420	AISI 420
2 Bonnet	JL 1040 (GG 25)	JS 1049 (GGG 40.3)
3 Disc	AISI 420	AISI 420
4 Stem	AISI 420	AISI 420
6 Packing Ring	Graphite	Graphite
7 Handwheel	JL 1030 (GG 20)	JL 1030 (GG 20)
10 Bolts *	5.6 – 5.2	5.6 – 5.2
11 Yoke Bushing	Carbon steel	Carbon steel
13 Packing gland	Carbon steel	Carbon steel
23 Stroke indicator	Carbon steel	Carbon steel
42 Retaining ring	Alaşımlı Çelik	Alaşımlı Çelik
43 Antifriction washer	Carbon steel C70	Carbon steel C70
61 Gasket	Grafit	Grafit
70 Pin	SS	SS
75 Washer	SS	SS
79 Washer	Carbon steel	Carbon steel
85 Handwheel nut	Carbon steel	Carbon steel

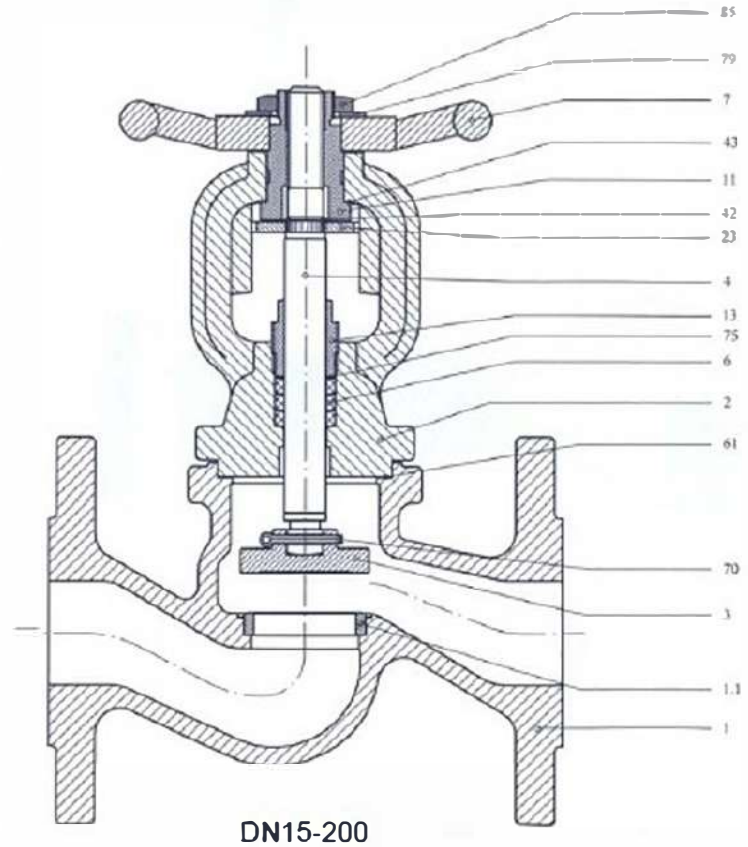

\*In PN 25 rating valves, Stud bolts and nuts are used.

Note: DN 250 valves including balanced disc is installed in pipeline in reverse direction shown with an arrow on the body .

VALFTEK®-017eng -- 12/2010®

تماس 24 ساعته حتی تعطیلات

Tel : ۰۲۱ ۶۶۴۷ ۹۴۸۶

Fax : ۰۲۱ ۸۹۷۷ ۹۳۷۳

مدیریت ۰۹۱۲ ۸۴۴ ۸۷۶۳  
 www.Controltak.com

شبکه های مجازی / ارسال استعلام ۰۹۳۵ ۴۴ ۷۹ ۱۱۰  
 Controltak@chmail.ir Controltak@gmail.com

 VALFTEK®

تلگرام / سروش @Controltak  
 اینستاگرام Control-Tak